

This drawing involves proprietary design rights of Tyco Electronics Corporation, and all design, manufacture, reproduction, use and sale rights regarding the same are expressly reserved. It is submitted for a specific purpose and the recipient by accepting this drawing, assumes custody and control and agrees to take reasonable precautions; (a) that this drawing will not be copied and reproduced, in whole or in part, or its contents revealed in any manner, or to any person except to meet the purpose for which it was delivered and (b) that any special features peculiar to this design will not be incorporated in other projects without the expressed written permission of Tyco Electronics Corporation.

REVISIONS			
EC	REV	DESCRIPTION	DATE
CPR	A	NEW RELEASE	08/01/05
---	A1	EDITORIAL CHANGE	12/02/05

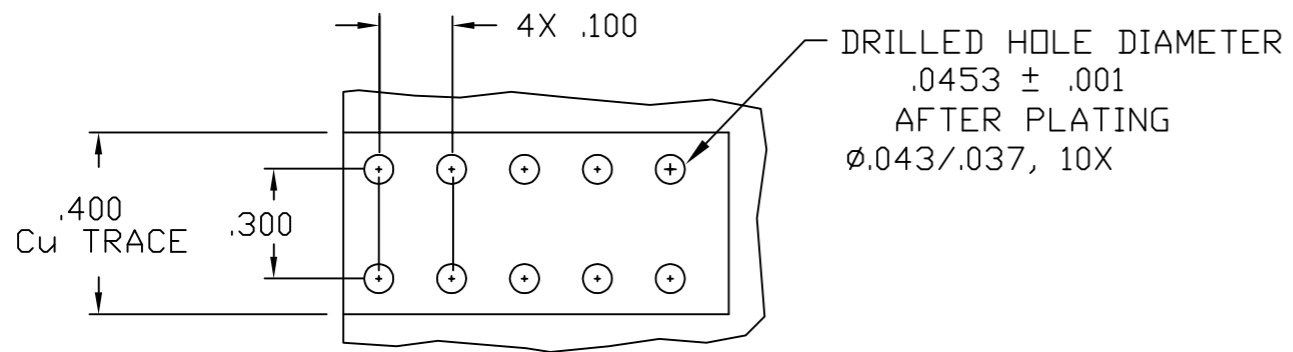

SUGGESTED PCB FOOTPRINT

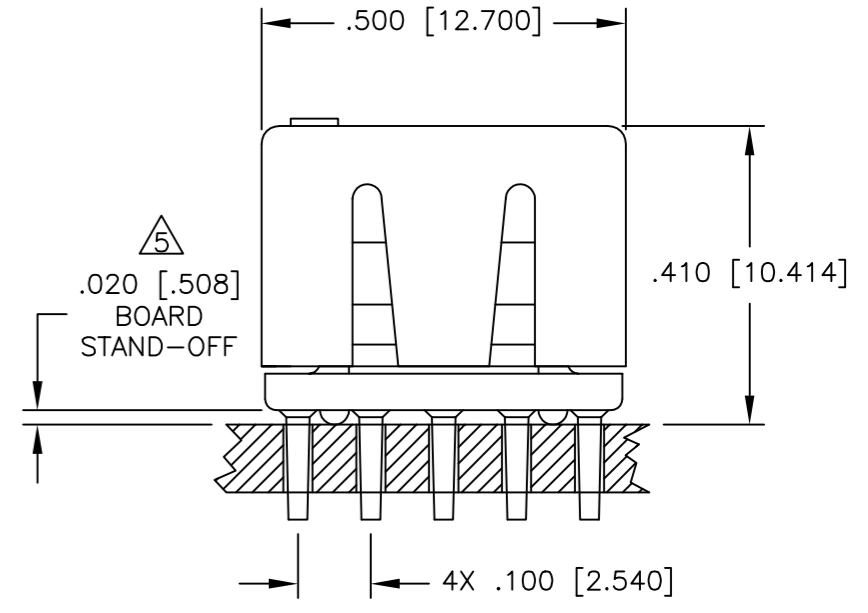
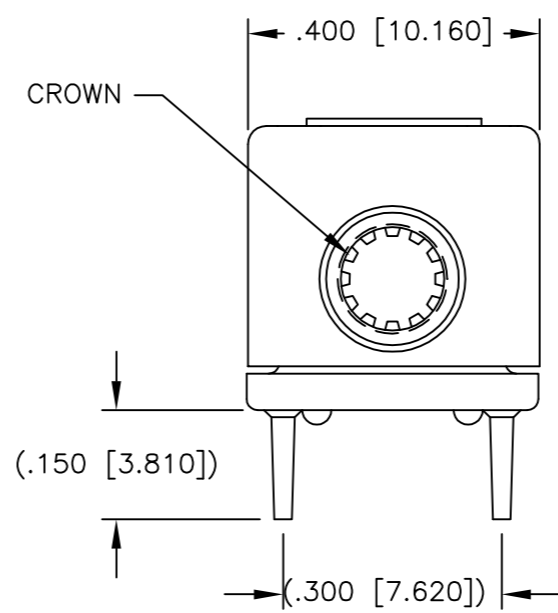

5 A FIVE-POUND (5lb) FORCES REQUIRED TO CORRECTLY SEAT THE CONNECTOR WITH PLATED THRU HOLES LESS THAN ϕ .040 INCH.

- 4. FINISH:
MODULE: SILVER PLATED.
CROWN: GOLD PLATED.
- 3. MATERIAL:
INSULATOR: POLYESTER, GLASS FILLED, UL 94 V-0 RATED, COLOR-BLACK.
MODULE: METAL CASTING.
CROWN: BECU

2. ITEMS PROVIDED TO THIS SPECIFICATION SHALL BE IDENTIFIED ON CONTAINER WITH THE FOLLOWING INFORMATION PART NUMBER AND DATE CODE OF MANUFACTURE.

1. PART NUMBER CHANGES AND OR DESIGN CHANGES AFFECTING ITEM INTERCHANGEABILITY REQUIRE PRIOR TYCO APPROVAL AND AUTHORIZATION BY REVISION TO THIS DRAWING.

NOTES: UNLESS OTHERWISE SPECIFIED

INCH OR INCH (MM) THIRD ANGLE PROJECTION UNLESS OTHERWISE SPECIFIED DIMENSIONS ARE IN INCHES (METRIC) TOLERANCES ANGLES \pm .5° DECIMALS .XXX \pm .020 .XX \pm	DRAWN LOVATO	DATE 08/01/05	 Tyco Electronics Corporation Menlo Park, Ca 94025 	
	CHECKED			TITLE ICCON SOCKET, PARALLEL 10 PIN FOOTPRINT, SOLDER STYLE PN 6643232-1
	APPROVED		SIZE B	DWG NUMBER C= 6643232
	APPROVED D. CHAU DCA APPROVED M. ALIM	12/02/05 12/02/05	REV. A1	ACAD FILE NUMBER C6643232A1.DWG
		DWG SCALE 4=1	SH 1 OF 1	